



AHEAD WORKING PAPER SERIES/DOCUMENT DE TRAVAIL

Potential Market Size and Impact of Hepatitis C Treatment in Low- and Middle-Income Countries

Maame Esi Woode
Mohammad Abu-Zaineh
Joseph Perriens
Françoise Renaud
Stefan Wiktor
Jean-Paul Moatti

Working Paper No. 03/2015

Potential market size and impact of hepatitis C treatment in low- and middle-income countries

Corresponding Author

- 1) Maame Esi Woode, PhD. INSERM-IRD-UMR 912 (SESSTIM), 23 Rue Stanislas Torrents, 13006 Marseille, France. E-mail: maame-esi.woode@inserm.fr. Tel: +33(0)496102865, Fax: +33 (0)491598924

Other Authors:

- 2) Mohammad Abu-Zaineh, PhD. INSERM-IRD-UMR 912 (SESSTIM), Faculty of Medicine and Aix-Marseille School of Economics (AMSE), Aix-Marseille University, 23 Rue Stanislas Torrents, 13006 Marseille, France. E-mail: mohammad.abu-zaineh@inserm.fr
- 3) Joseph Perriens, PhD. Department of HIV and Viral Hepatitis, World Health Organization, Avenue Appia 20, 1211 Geneva 27, Switzerland. E-mail: perriensj@who.int
- 4) Françoise Renaud, Pharm.D. Department of HIV and Viral Hepatitis, World Health Organization, Avenue Appia 20, 1211 Geneva 27, Switzerland. E-mail : renaudf@who.int
- 5) Stefan Wiktor, MD, Global Hepatitis Programme, World Health Organization, Avenue Appia 20, 1211 Geneva 27, Switzerland. E-mail : wiktors@who.int
- 6) Jean-Paul Moatti, PhD, INSERM-IRD-UMR 912 (SESSTIM), Aix-Marseille University, 23 Rue Stanislas Torrents, 13006 Marseille, France. E-mail: jean-paul.moatti@inserm.fr

Abstract

The introduction of direct-acting antiviral agents (DAAs) has made hepatitis C infection curable in the vast majority of cases and the elimination of the infection possible. Although initially too costly for large-scale use, recent reductions in DAA prices in some low- and middle-income countries (LaMICs) has improved the prospect of many people having access to these drugs/medications in the future. This paper assesses the pricing and financing conditions under which the uptake of DAAs can increase to the point where the elimination of the disease in LaMICs is feasible. A Markov simulation model is used to study the dynamics of the infection with the introduction of treatment over a 10-year period. The impact on HCV-related mortality and HCV incidence is assessed under different financing scenarios assuming that the cost of the drugs is completely paid for out-of-pocket, or reduced through either subsidy or drug price decreases. It is also assessed under different diagnostic and service delivery capacity scenarios separately for low-income (LIC), lower-middle-income (LMIC), and upper-middle-income countries (UMIC). Monte-Carlo simulations are used for sensitivity analyses. At a price of US\$ 1680 per 12-week treatment duration (based on negotiated Egyptian prices for an all oral two-DAA regimen), most of the people infected in LICs and LMICs would have limited access to treatment without subsidy or significant drug price decreases. However, people in UMICs would be able to access it even in the absence of without subsidy. For HCV treatment to have a significant impact on mortality and incidence, a significant scaling-up of diagnostic and service delivery capacity for HCV infection is needed.

Keywords: Developing countries; Direct-Acting Antiviral Agents (DAA); Hepatitis C; Markov simulation; Universal access.

INTRODUCTION

The World Health Organisation (WHO¹) estimates that between 130 and 150 million people globally have chronic hepatitis C virus (HCV) infection [1]. After contracting HCV, between 55% and 85% develop chronic HCV [2,3,4]. As a result, about 704 000 people die, each year, of HCV-related liver diseases [5]. HCV is found worldwide with most (72%) infections occurring in middle-income countries (MICs), 13% in low-income countries (LICs) and the remaining 15% in high-income countries (HICs) [6,7]. The spread of HCV is largely explained by the use of unsafe injection equipment, and for this reason persons who inject drugs and populations exposed to non-sterile injection and other invasive medical equipment in the healthcare setting are at greater risk. As the infection is also sexually transmitted, people at high risk of acquiring sexually transmitted infections (STI) and human immunodeficiency virus (HIV) [7] are also at risk of HCV infection.

Most people with HCV are not aware of their status: less than 50% in HICs, and less than 10% in LICs and lower-middle-income countries (LMICs). Those in touch with health services because of HIV or because they are symptomatic are more likely to be diagnosed [8,9,10].

To prevent the spread of HCV, WHO recommends actions reducing exposure to HCV in healthcare settings (such as ensuring safety of injections), and implementing harm reducing interventions for drug users [11]. Until recently, the use of antiviral treatment to curtail the extent and impact of the disease was not given high priority, as the existing treatments with interferon and ribavirin are expensive, relatively toxic, and not very effective. The advent of all oral combination treatment with Direct-Acting Antivirals (DAAs) in 2014 dramatically

¹Abbreviations CTP: capacity-to-pay, DAA: direct-acting antiviral agents, GDP: gross domestic product, HCC: hepatocellular carcinoma, HCV: hepatitis C virus, HICs: High-income countries, HIV: human immunodeficiency virus, LaMICs: low- and middle-income countries, LICs: low-income countries, LMICs: lower-middle-income countries, OOPE: out-of-pocket expenditure, SIR: susceptible-infected-removed, SVR: sustained virological response, UMICs: upper-middle-income countries, WDI: world development indicators, WHO: world health organization

changed this, as it simplified treatment, reduced side effects, and increased cure rates to approximately 95% [12]. This made eliminating HCV transmission possible for the first time.

DAAs are currently too expensive for governments worldwide to deliver on their promise to cure and eliminate the disease. Nevertheless, price decreases for HCV drugs have already been announced for some DAAs in a few LICs, and in the future voluntary licensing will increase the availability of generic DAAs [12]. This offers some hope that universal access to HCV treatment might be possible. We modelled the affordability and medical eligibility conditions under which HCV treatment can be optimally used to reduce HCV-related mortality and incidence in low- and middle-income countries (LaMICs).

MATERIALS AND METHODS

A Susceptible-Infected-Removed (SIR) epidemic model was used to construct a compartmental Markov model assessing the evolution of the HCV epidemic [13,14,15]. Re-infection rates can be high among people who inject drugs (PWID), but PWID only represent approximately 5.4% of all persons with HCV infections [16, 17]. Re-infection rates are much lower among non-PWID [18,19]. In the absence of relevant data on mixing and the rate of re-infection in treated populations, re-infection is assumed not to occur in the model and that the population mixes homogeneously, that is to say, they randomly come into contact with HCV infection. The outcomes are the number of individuals receiving treatment, the number of HCV-related deaths, and the disease incidence following the introduction of treatment.

The model is built in two parts. The first, represented by the lower line of events in [Figure 1](#), simulates the natural history of the disease while the second, represented by the 2 upper lines, simulates the effect of treatment strategies. Both parts follow a yearly cycle.

The population is assumed to be composed of seven groups: susceptible, acutely infected, immune (including the cured), chronically infected and never treated (comprising 5 subgroups

F0, F1, F2, F3, and F4, in which the number following the “F” represents the stage of fibrosis development), those with decompensated cirrhosis or with hepatocellular carcinoma (HCC), and those who experience HCV-related death.

Given the lack of initial incidence data, a steady-state population incidence is assumed, hence, the numbers within each sub-population remain unchanged [20]. The yearly incidence is calculated as

$$I = \left(\frac{P}{1 - P} \right) \left(\frac{1}{DR} \right)$$

where I the incidence rate , P is the prevalence rate and DR the disease duration (40 years). This is a necessary assumption that implies a more or less stable population, despite the fact that we allow for HCV and non-HCV related mortality as well as immigration and emigration, which would imply a not so stable population. Further clinical studies on the incidence of the disease in developing countries are needed for this assumption to be relaxed.

The annual rate of natural population growth, obtained from *the World Bank Population Projection* [21] is used to estimate the size of the population each year. Given the homogeneity and no re-infection assumptions, the rate at which individuals join the susceptible population is equal to the birth rate.

[Table 1A](#) presents the initial fibrosis distribution of those chronically HCV-infected, based on prevalence data for Egypt [22]. Due to absence of data on HCV-related decompensated cirrhosis and HCC distribution we assume that the ratio of people with HCV-related decompensated cirrhosis and HCC to those with chronically infected HCV is approximately 1% and 0.5%, respectively. The transition probabilities between disease states are given in [Table 1B](#). Irrespective of infection status, individuals are assumed to exit from all groups at the natural death rate. The outcome of introducing treatment at each fibrosis stage is represented by the annual number treated (T0 to T4), which represents by the number of people cured and

the number of people treated but not cured ($\hat{F}0$ to $\hat{F}4$). The latter are assumed to progress to decompensated cirrhosis and hepatocellular carcinoma with the same rate as untreated patients.

Treatment discontinuation and retreatment is not allowed for in the model. Therefore, once treatment is accepted, individuals follow through to the end and if they do not achieve sustained virological response (SVR) after treatment has ended, they are not retreated. People are assumed to be cured (and i.e. remain free from re-infection) when they reach SVR. The SVR rates used are summarised in [Table 1C](#).

Each country cohort was analysed separately over a 10-year period using prevalence rates estimated by Gower et al [23]. Results were aggregated by subgroup of LIC, LMIC and UMICs, as classified by the World Bank in 2015 [24].

Given that in LaMICs only a small percentage of those with chronic HCV would be diagnosed, we assume, in the absence of data, an initial diagnosis rate (the number of persons newly diagnosed) of 1% for LICs, 3% for LMICs and 5% for UMICs. We also assume that the number of individuals diagnosed increases by a factor of 1.2 in subsequent years. This estimate of 1.2 is based mainly on results observed for HIV studies where demand for CD4 testing was expected to increase by a factor of 1.1-2.2 per year from 2013-2018. Demand for viral load testing was expected to increase by a factor of 1.2-4.4 per year for the same time frame. The demand for HIV testing was expected to increase by a factor of 1.1-1.5 per year [25].

Eligibility for treatment is assumed to depend on the fibrosis stage. In the base case scenario (based on the 2014 WHO recommendations [26]) only patients with ‘advanced fibrosis and cirrhosis (Metavir stages F3 and F4) are assumed to be eligible for, and offered, treatment.

Not everyone diagnosed and eligible for treatment starts it. Several factors, including individuals’ capacity-to-pay (CTP), severity of the disease (stage of disease) and trust in the remedies etc) influence treatment uptake. The first factor considered in the model is the users’ CTP. Data on the share of GDP held by each income quintile from the World Development

Indicators (WDI) are used as proxies for CTP. This is then divided by the number of individuals in each income group to estimate the income per capita per quintile. GDP is assumed to increase over time, at rates obtained from *the World Economic Outlook Database for April (2014)*. A moving average is used to estimate the growth rates for the years after 2019. It is assumed that individuals can afford the treatment if its cost does not exceed 40% of their CTP, which corresponds to the conventional definition of the threshold of catastrophic health expenditure [27,28].

It is further assumed that a 10% decrease in prices leads to an increase in demand of about 2% for each income group provided they have sufficient income to afford the treatment. This is in line with previous studies, which found that the price elasticity of demand for healthcare is about -0.2 (95% CI (-0.04 to -0.75)) [29].

After sofosbuvir - one of the DAAs currently in use - was given market authorization by the US Food and Drug Administration [12], negotiations between Gilead Sciences and the government of Egypt followed, in which a reduced price US\$ 840 for a 12-week course of sofosbuvir was agreed [30]. If Ledipasvir, another DAA, were made available for the same price, a 12-week treatment with two DAAs would cost approximately US\$ 1680. We assumed this to be the cost of a 12-week dual drug DAA treatment course in our model.

As people infected with genotypes 2 and 3 require a 24-week treatment course [31,32], which therefore costs twice as much, we adjusted the treatment cost in each country to take into account country-specific genotype distribution, from Messina and colleagues [33] (data not shown – available in supplemental Table A and B). Akin to the fall in the global price of ARV medications observed from 2003 to 2011 the average cost of treatment is assumed to fall at a rate of 3.8% each year [34].

As health systems in developing countries are underfunded and understaffed [35], we assumed that, in the initial year, the health system would be capable of taking care of only 5%

of those diagnosed. Not all of those diagnosed would demand treatment. In the baseline scenario, the capacity of the health system is assumed to increase over time by a factor of 1.2 each year. For instance, if in 2014, the health system can provide the treatment to only 5 of 100 infected individuals, then in 2015 it can take care of $6(1.2*5)$ individuals and $7.2(1.2*6)$ individuals in 2016 etc. If the capacity is lower than the number of those diagnosed, those offered treatment, and those able to pay for treatment, then those with a higher fibrosis stage are considered first for treatment.

Scenarios Presented

The first scenario presented in this paper is the “base case” scenario. In keeping with the more conservative version of the 2014 WHO recommendations, only those with fibrosis stages 3 and 4 are eligible for treatment. It assumes that only 1%, 3% and 5% of HCV- infected patients are diagnosed in LICs, LMICs, and UMICs, respectively, with the proportions increasing over time by a factor 1.2 per year. Only 5% of those diagnosed and eligible are offered treatment in year 1, increasing by a factor of 1.2 each subsequent year, to take into account health systems’ increased capacity to offer the service. Treatment costs are assumed to be US\$ 1680 for a 12-week treatment course (adjusted for the genotype distribution in the infected population) and the number of people accepting it increases 2% when the cost decreases by 10%.

The second scenario has the same assumptions, with the exception that, instead of limiting treatment to patients with fibrosis stages 3 and 4, all patients with chronic infection are eligible for treatment.

In the third scenario, a 25%, 50%, 75% and 100% subsidy of the cost of drugs is introduced, but eligibility is the same as that for the baseline scenario.

In a fourth scenario people with fibrosis stages 3 and 4 are eligible for treatment, but the ability to diagnose and the capacity of the health system to offer services is allowed to increase by a factor of 3 (does not mean the number of patients are tripling but rather that the health

system is able to take care of a maximum of 3 times the people they had in charge the year before), while drug costs are reduced (through subsidy or price decrease) 80%, which corresponds to an initial price of US\$ 400 for a 12-week course of dual combination treatment, which equals the upper boundary of their reported minimum production cost [36].

The fifth and final scenario has the same assumptions as the fourth scenario, except that all patients with chronic infection are eligible for treatment. A full description of the various assumptions can be found in [Table 1a](#) to [Table 1d](#) and [Figure 2](#).

Sensitivity analysis

A Monte-Carlo simulation was carried out for the scenario in which individuals with fibrosis stages 0 to 4 are eligible for treatment, and in which the initial rate of diagnosis and the initial health system capacity are set at 5% with an increment factor of 1.2. The transition probabilities and SVR rates were allowed to randomly vary between their 95% confidence intervals.

RESULTS

Of the 132 LaMICS in the World Bank Classification, 116 were included in the model (see supplementary [Table B](#)). Sixteen countries, which represent an estimated 1.78% of all persons with HCV infection, were not included because of missing financial data. As the total number of HCV infected people in those countries is very small, their omission has minimal impact on the results. Full results are available in supplementary [Tables D-F](#) and [Figure A](#).

Low-Income Countries

Results for LICs are shown in [Table 2](#) and summarized in [Figure 3](#). The uptake of HCV treatment in LIC is predicted to be very limited in the base case scenario: 7081 cases treated over a 10-year period. Not surprisingly, the impact on the number of HCV-related deaths and incidence is also limited.

Expanding treatment eligibility from fibrosis stages 3 and 4 to all people with chronic HCV (scenario 2) does not change this picture, as demand is limited both by the health system's ability to provide HCV services and as the cost of drugs remains unaffordable for the great majority of patients.

The effect of reducing out-of-pocket expenditure (OOPE), which is modelled in scenario 3 with no measures to improve the health system's diagnostic and service delivery capacity, is almost linear –approximately doubling for every 25% reduction until OOPE is reduced by 75%. When there is no OOPE for the drugs, the uptake is predicted to increase by a factor 1.04, compared with reducing OOPE by 75%. However, even with no OOPE the number of deaths and incidence would be reduced by only 1.37% and 0.37%, respectively, over a 10-year period.

It is predicted that the effect of alleviating health system barriers, illustrated in scenario 4 for people with fibrosis stages 3 and 4, and for all people with chronic HCV in scenario 5, for a level of OOPE reduced by 80%, is a dramatic one. The model predicts that approximately 18.81% to 19.09% of the deaths and 7.84% to 19.47% of the new cases in the base case scenario would be avoided.

Lower-Middle-Income countries

Results for LMICs are shown in [Table 3](#) and summarized in [Figure 3](#). In the baseline scenario almost 787 000 people would access treatment. Offering the treatment to all people with chronic HCV, with payment of the full cost of the drugs by the patients, as shown in scenario 2, is seen to almost increase the uptake by a factor of 1.05. However, this has only a minimal impact on the number of deaths, and on incidence, which are predicted to decrease by only 0.00% and 0.01%, respectively, over the 10-year projection horizon of the model.

The outcomes of progressively decreasing OOPE for the drugs are shown in scenario 3, which illustrates that the number of people accessing treatment remains limited as long as

OOPE equals or exceeds 75% of the drug costs. When there is no OOPE for the drugs, the impact on the number of deaths and the incidence increases to 2.10% and 0.51%, respectively.

As with the scenarios in LICs, the effect of alleviating health system barriers, illustrated in scenario 4 for people with fibrosis stages 3 and 4, and for all people with chronic HCV in scenario 5, for a level of OOPE reduced by 80%, is predicted to be dramatic. The number of HCV-related deaths decreases by 39.95% when treatment is offered to people with fibrosis stages 3 and 4, and by 40.08% when it is offered to all people with chronic HCV, the incidence decreases by 15.08% and 33.91%, respectively.

Upper-middle-income countries

Results for UMICs are shown in [Table 4](#) and summarized in [Figure 3](#). Even in the baseline scenario, in which treatment is not subsidized, there is significant uptake of HCV treatment: it would exceed 1 million people over a 10-year period when offered to those with fibrosis stages 3 and 4 (Scenario 1) or to all those with chronic HCV (Scenario 2).

Reducing the level of OOPE, as illustrated in Scenario 3, shows no impact on uptake, because at the price levels assumed in the model, the majority of people with fibrosis stage 3 or 4 and offered treatment would be able to access it.

The effect of alleviating health system barriers, illustrated in scenario 4, for people with fibrosis stages 3 and 4, and for all people with chronic HCV in scenario 5, for a level of OOPE reduced by 80%, is again predicted to be dramatic. Over a 10-year period, the number of HCV-related deaths would decrease 46.38%, when treatment is offered to people with fibrosis stages 3 and 4, and 46.40 % when it is offered to all people with chronic HCV. Incidence would decrease by 17.10% and 39.10%, respectively.

Sensitivity analysis

The Monte-Carlo simulation results indicated that our results are robust to changes in transition probabilities and SVR rates, with the average number of the never-treated patients not varying significantly from the values obtained using the initial transition probabilities and SVR rates. Thus, the uncertainties associated with these groups of variables do not create very large discrepancies. Please refer to [Table 5](#) for summary results and [Tables G - I](#) in the supplementary appendix for full results.

DISCUSSION

This paper assesses the effect of different assumptions on the number of people likely to be treated with DAAs for HCV in LaMICs, and examines the related impact on HCV-related mortality and incidence.

The baseline model and the scenario expanding the eligibility for DAAs to all patients with chronic HCV demonstrate that, at the lowest prices agreed for Egypt and Pakistan, and in the absence of full subsidy of the cost of DAAs, the uptake of DAA will be very limited in LICs and LMICs. Consequently, HCV-related mortality and incidence are not substantially decreased. Limiting OOPE for the drugs - by either subsidising their cost or producing them much less expensively – was predicted to not have a major impact on the number of deaths and incidence in LICs and LMICs, unless more than 75% of their full cost was covered. However, even when there is no OOPE for the drugs, the predicted impact on death and incidence was limited. Along with subsidizing or reducing the cost of the drugs, improving the health system’s diagnostic and care delivery capacity is a critical requirement to reduce HCV-related mortality and incidence.

At the price levels assumed in our model, decreasing OOPE for the drugs did not appear to affect the uptake in UMICs. It remains to be seen, however, whether UMICs will be able to access DAAs at the prices assumed in our model, as at least one company producing DAAs

announced that it will negotiate 3-tier pricing system [37]. This suggests that UMICs might fall in the middle tier, where prices will likely be higher. Furthermore, in several UMICs HCV infection is prevalent in people who inject drugs, a population who might have less discretionary CTP, and for whom treatment would need to be subsidized if HCV is to be contained.

As illustrated by scenarios 4 and 5, the greatest impact on treatment uptake and incidence would result from subsidising treatment, while at the same time increasing the health system's diagnostic and delivery capacity. Moreover, comparison of those 2 scenarios suggests that in order to have a major impact on incidence, treatment should be offered to everyone with chronic HCV. While this would cost more in terms of drugs and service delivery, it would facilitate access to treatment, because the cost and complexity of fibrosis staging would no longer create a bottleneck. Assuming that treatments are pan-genotypic and therefore do not require genotyping, if treatment is offered to all people with chronic HCV, all one would need to initiate treatment is a diagnosis of chronic HCV, which could be established by documenting persistent viral replication with HCV core antigen tests or a nucleic acid test (PCR).

The question then is whether the global community is willing to finance global scale-up of access to DAAs. For LICs, about US\$ 844 million would be needed to cover the cost of the 80% subsidy for our scenario 5, in which all those with chronic HCV are eligible for treatment, for the first 5 years of the model. Approximately US\$ 13 billion would be required to cover the full drug costs over the entire 10-year period. In LMICs the cumulative cost of treating all with chronic HCV would be approximately US\$ 9 billion by year 5 and US\$ 49 billion by year 10. These costs are of the same order of magnitude those of other donor-funded disease priorities like HIV (about US\$ 8.1 billion in 2013 alone [38,39], and would be considerably less if health systems could not scale-up their diagnostics and service delivery capacity as quickly as we assumed in our model, or if eligibility for treatment were limited to fibrosis stages 3 and 4, or

indeed if the cost of DAA's decreased more quickly than we assumed in our model, as some claim is possible [36]. As the cost of treating HCV infections would appear manageable, it should be noted that several LMICs, including Egypt, Pakistan and Mongolia, have decided to start HCV treatment programmes.

It is interesting to compare our results with those of Obach et al. (2015) [40] whose objective was to maximize Life Years Saved given a fixed and limited number of treatment slots. Our paper, on the other hand, looks at the combination of treatment costs and eligibility criteria that would result in the greatest number of persons treated and thus maximally reduce mortality and incidence. Their results imply that individuals at Fibrosis stages F3 and F4 should be given a priority in order to save the most life years. We find that treating only individuals at Fibrosis stage F3 and F4 may save lives, but that the greatest effect on both mortality and incidence is obtained only when those at the early stages are also taken into consideration.

Several study limitations must be acknowledged. First, in spite of the fact that HCV infections are known to disproportionately affect persons who inject drugs and men who have sex with men, homogenous mixing is assumed, giving both these two groups and the general population the same probability of becoming infected. In addition, due to a lack of data from other countries, we used the distribution of fibrosis stages based on data from Egypt. It is unknown to what degree the distribution of fibrosis stages differs in different countries. Sensitivity analysis results presented in [Table 5](#) indicate that the results do not vary greatly when parameters are allowed to vary at the same time within their respective confidence intervals.

Second, only drug costs were considered: costs of increasing health system's diagnostic and service delivery capacity were ignored. There is a need to admit that there is some uncertainty about the future cost of DAAs. While some argue that drug costs will decrease faster than assumed [30], the real drug costs may be higher than those we projected. In the latter case, it

may take longer to attain universal access to HCV medications. We did not specifically address whether for low-income populations within LMICs and UMICs there is a need to build additional financial protection schemes (like income supplementation) or whether specific service delivery investments such as outreach services are needed for most vulnerable populations. Both would increase the cost of HCV treatment.

Third, in view of their major impact on model outcomes, it is also critical to note that the absence on data forced us to choose arbitrary levels of constraint in diagnostic and service delivery capacity.

Fourth, there is a great deal of uncertainty about the epidemiology and natural history of HCV infection. While it is estimated that HCV-related worldwide mortality is about 704 000 persons/year [5], our estimate of HCV-related deaths is slightly higher. This is largely due to the transition probabilities used in our model [41]. In turn this suggests that either the mortality obtained by the Global Burden of Disease study [5] is underestimated, or that the transition probabilities are on the high side. Without better information on country-specific natural history of HCV infection, and better assessment of its impact on mortality, it is not possible to suggest a better way of dealing with this issue. However, even if the impact on the number of deaths in our model were overestimated, the tendency of decreasing death rates with increasing access to treatment would still be confirmed.

Finally, the model assumes that all patients who can afford treatment would start if offered, regardless of any side-effects or the stage of their infection, and that cure rates will be high. Although, new DAAs are shown to have limited side-effects, patients' acceptability of treatment may vary depending on other unobservable factors. Not all service providers would comply with recommendations to offer all chronically infected patients' treatment if they are not convinced that it confers benefit to their patients' well-being. And in real life, the cure rates

might be lower than those reported in clinical trials. In the absence of reliable data on these attrition rates we refrain from speculating how substantial they might be.

In spite of its limitations, our model provides strong suggestions that DAAs can play an important role in controlling the HCV epidemic, and gives a first assessment of what is required to realize their potential in LaMICs. It also provides a strong indication that in LICs and LMICs, subsidies or much lower prices will be needed to make DAAs affordable. Furthermore, it underlines that it is critical to strengthen the ability of the health system to diagnose HCV infection and manage treatment in order to maximize its potential impact on the HCV epidemic. The latter will also help prevent the spread of HCV. It is therefore paramount that infected people and their health service providers combine their advocacy and technical skills to mobilise the political momentum and health system inputs needed to expand access to DAAs. Finally, one should realize that treatment is only one side of the story: the prevention of HCV infections, mainly by securing injection safety, ensuring a clean blood supply, and implementing harm reduction interventions targeting people who inject drugs, are also required.

FUNDING

This work was initiated with a grant from WHO to the ANRS. It was completed thanks to the support of the A*MIDEX project (no. ANR-11-IDEX-0001-02) funded by the “Investissements d’Avenir” French Government program, managed by the French National Research Agency (ANR).

COMPETING INTEREST

The authors declare that they have no competing interests.

AUTHORS’ CONTRIBUTION

1. Maame Esi Woode: Literature search, figures, study design, data collection, data analysis, data interpretation and writing.
2. Mohammad Abu-Zaineh: Literature search, figures, study design, data collection, data analysis, data interpretation and writing.
3. Joseph Perriens: Literature search, study design, data interpretation and writing.
4. Françoise Renaud: Study design, data interpretation and writing.
5. Stefan Wiktor: Study design.
6. Jean-Paul Moatti: Study design, data analysis and data interpretation.

ACKNOWLEDGEMENTS

We are grateful for helpful comments and suggestions on earlier drafts of the paper by Patrizia Carrieri, Arnaud Fontanet, Daniel Wolfe and Els Torreele.

REFERENCES

1. Lavanchy D. The Global Burden of Hepatitis C. *Liver International*. 2009; 29: 74-81.
2. Deuffic S, Buffat L, Poynard T, Valleron AJ. Modeling the Hepatitis C Virus Epidemic in France. *Hepatology*. 1999; 29(5): 1596-1601.
3. Kamal SM. Acute Hepatitis C: A Systematic Review. *American Journal of Gastroenterology*. 2008; 103: 1283-1297.
4. Lehman EM, Wilson ML. Epidemic Hepatitis C Virus Infection in Egypt: Estimates of Past Incidence and Future Morbidity and Mortality. *Journal of Viral Hepatitis*. 2009; 16(9): 650-658.
5. GBD 2013 Mortality and Causes of Death Collaborators. Global, Regional, and National Age-Specific All-Cause and Cause-Specific Mortality for 240 causes of Death 1990-2013: A Systematic Analysis for the Global Burden of Disease Study 2013. *Lancet*. 2015; 385: 117-171.
6. Lavanchy D. Evolving Epidemiology of Hepatitis C Virus. *Clinical Microbiology Infection*. 2011; 17: 107-115.
7. Médecins du Monde. New treatments for hepatitis C virus: strategies for achieving universal access. [Online]. Available from: http://hepcoalition.org/IMG/pdf/web_daas_strategies_for_achieving_universal_access_en.pdf.
8. Cornberg M, Razavi H, Alberti A, E B, M B, Cooper C et al. A Systematic Review of Hepatitis C Virus Epidemiology in Europe, Canada and Israel. *Liver International*. 2011; 31: 30-60.
9. Kershenovich D, Razavi H, Bessone F, Coelho H, L D, et al. Trends and Projections of Hepatitis C Virus Epidemiology in Latin America. *Liver International*. 2011;(31): 18-29.
10. Sievert W, Altraif I, Razavi H, et al. A systematic review of hepatitis C virus epidemiology in Asia, Australia and Egypt. *Liver International*. 2011; 31: 61-80.
11. WHO. Hepatitis C Fact Sheet no. 164. [Online].; 2014 [cited 2015 03 4]. Available from: <http://www.who.int/mediacentre/factsheets/fs164/en/>.
12. Pawlotsky J. New Hepatitis C Therapies: The Toolbox, Strategies, and Challenges. *Gastroenterology*. 2014; 146: 1176-1192.
13. Shepard CW, Finelli L, Alter MJ. Global Epidemiology of Hepatitis C Virus Infection. *The Lancet Infectious Diseases*. 2005; 5: 558-567.
14. Elbasha E. Model for Hepatitis C Virus Transmissions. *Mathematical Biosciences and Engineering*. 2013; 10(4): 1045-1065.
15. Hajarizadeh B, Grebely J, Dore GJ. Epidemiology and Natural History of HCV Infection. *Nature Reviews: Gastroenterology & Hepatology*. 2013; 10: 553-562.
16. Mohd Hanafiah K, Groeger J, Flaxman AD, WST. Global Epidemiology of Hepatitis C Virus Infection: New Estimates of Age-Specific Antibody to HCV Prevalence. *Hepatology*. 2013; 57(4): 1333-1334.
17. Nelson PK, Mathers BM, Cowie B, Hagan H, Des Jarlais D, Horyniak D, et al. Global Epidemiology of Hepatitis B and Hepatitis C in People who Inject Drugs: Results of Systematic Reviews. *Lancet*. 2011; 378(9791): 571-583.

18. Averhoff FM, Glass N, Holtzman D. Global Burden of Hepatitis C: Considerations for Healthcare Providers in the United States. *Clinical Infectious Diseases*. 2012; 55(suppl 1): S10-s15.
19. Hill AM, Saleem J, Heath KA, Simmons B. Effects of Sustained Virological Response (SVR) on the Risk of Liver Transplant, Hepatocellular carcinoma, Death and Re-infection: Meta-Analysis of 129 Studies in 23,309 Patients with Hepatitis C Infection. *Hepatology*. 2014; 60(4 (suppl)): 218A-219A.
20. Pearce N. Effect measures in prevalence studies. *Environmental Health Perspectives*. 2004; 112: 1047-1050.
21. World Bank Group. Population Estimates and Projections. [Online].; 2014 [cited 2014 05 01]. Available from: <http://data.worldbank.org/data-catalog/population-projection-tables>.
22. El-Kamary SS, Mohamed MM, El-Raziky M, Shardell MD, Shaker OG, ElAkel WA, et al. Liver Fibrosis Staging Through a Stepwise Analysis of Non-Invasive Markers (FibroSteps) in Patients with Chronic Hepatitis C Infection. *Liver International*. 2013; 33: 982-990.
23. Gower E, Estes C, Blach S, Razavi-Shearer K, Razavi H. Global Epidemiology and Genotype Distribution of the Hepatitis C Virus Infection. *Journal of Hepatology*. 2014; 61: S45-57.
24. World Bank Group. Country and Lending Groups. [Online].; 2014 [cited 2014 05 01]. Available from: <http://data.worldbank.org/about/country-and-lending-groups>.
25. World Health Organization. HIV diagnostic tests in low- and middle-income countries: Forecasts of global demand for 2014-2018. Geneva.; 2015.
26. WHO. WHO Guidelines for the Screening, Care and Treatment of Persons with Hepatitis C Infection. Geneva.; 2014.
27. Xu K, Evans DB, Kawabata K, Zeramdini R, Klavus J, Murray CJL. Household catastrophic health expenditure: a multicountry analysis. *Lancet*. 2003; 362: 111-117.
28. Wagstaff A, van Doorslaer E. Catastrophe and impoverishment in paying for health care: with applications to Vietnam 1993-1998. *Health Economics*. 2003; 12: 921-934.
29. Liu S, Chollet D. Price and Income Elasticity of the Demand for Health Insurance and Health Care Services: A Critical Review of the Literature. Washington DC: Mathematica Policy Research, Inc.; 2006.
30. WHO. Database on procurement of HIV and hepatitis products. [Online].; 2015 [cited 2015 02 09]. Available from: <http://www.who.int/hiv/pub/amds/hiv-hep-procurement-database/en/>.
31. Lok AS, Grdiner DF, Lawitz E. Preliminary Study of Two Antiviral Agents for Hepatitis C Genotype 1. *The New England Journal of Medicine*. 2012; 366(3): 216-224.
32. Jacobson IM, Gordon SC, Kowdley KV, Yoshida EM. Sofosbuvir for Hepatitis C Genotype 2 or 3 in Patients without Treatment Options. *The New England Journal of Medicine*. 2013; 368(20): 1867-1877.
33. Messina JP, Humpherys I, Flaxman A, Brown A, Cooke GS, Pybus OG, et al. Global Distribution and Prevalence of Hepatitis C Virus Genotypes. *Hepatology*. 2015; 61: 77-87.
34. WHO. Global Price Reporting Mechanism Database. [Online].; 2014 [cited 2014 05 01]. Available from: <http://apps.who.int/hiv/amds/price/hdd/>.

35. Kruk ME. Emergency preparedness and public health systems lessons for developing countries. *American Journal of Preventive Medicine*. 2008; 34(6): 529-534.
36. Hill A, Khoo S, Fortunak J, Simmons B, Ford N. Minimum Costs for Producing Hepatitis C Direct-Acting Antivirals for Use in Large-Scale Treatment Access Programs in Developing Countries. *Clinical Infectious Diseases*. 2014; 58(7): 928-936.
37. Gilead Sciences. Hepatitis B and C Treatment Expansion Fact Sheet. [Online].; 2015 [cited 2015]. Available from: <http://www.gilead.com/responsibility/developing-world-access/viral%20hepatitis>.
38. UNAIDS & The Henry J. Kaiser Family Foundation. Financing the Response to HIV in Low- and Middle-Income Countries: International Assistance from Donor Governments in 2013. UNAIDS & The Henry J. Kaiser Family Foundation; 2014.
39. Jayasekera CR, Barry M, Roberts LR, Nguyen MH. Treating Hepatitis C in Lower-Income Countries. *The New England Journal of Medicine*. 2014; 370(20): 1869-1871.
40. Obach D, Yazdanpanah Y, Esmat G, Avihingsanon A, Sewedar S, Durier N, et al. How to Optimize Hepatitis C Virus Treatment Impact on Life Years Saved in Resource-Constrained Countries. *Hepatology*. 2015; 62(1): 31-39.
41. Hagan L, Sulkowski MS, Schinazi RF. Cost Analysis of Sofosbuvir/Ribavirin Versus Sofosbuvir/Simeprevir for Genotype 1 Hepatitis C Virus in Interferon-Ineligible/Intolerant Individuals. *Hepatology*. 2014; 60: 37-45.
42. Thein HH, Yi Q, Dore GJ, Krahn MD. Estimation of Stage-Specific Fibrosis Progression Rates in Chronic Hepatitis C Virus Infection: A Meta-Analysis and Meta-Regression. *Hepatology*. 2008; 48: 418-431.
43. Coffin PO, Dcott JD, Golden MR, Sullivan SD. Cost-effectiveness and population outcomes of general population screening for hepatitis C. *Clinical Infectious Diseases*. 2012; 54: 1259-1271.
44. Dienstag JL, Ghany MG, MTR, Di Bisceglie AM, Bonkovsky HL, Kim HYea. A prospective study of the rate of progression in compensated, histologically advanced chronic hepatitis C. *Hepatology*. 2011; 54: 396-405.
45. Bruno S, Zuin M, Crosignani A, Rossi S, Zadra F, Roffi L, et al. Predicting mortality risk in patients with compensated HCV-induced cirrhosis: a long-term prospective study. *American Journal of Gastroenterology*. 2009; 104: 1147-1158.
46. Liu S, Cipriano LE, Holodniy M, Owens DK, Goldhaber-Fiebert JD. New protease inhibitors for the treatment of chronic hepatitis C: a cost-effectiveness analysis. *Annals of Internal Medicine*. 2012; 156: 279-290.
47. Fattovich G, Giustina G, Degos F, Tremolada F, Diodati G, Almasio P, et al. Morbidity and mortality in compensated cirrhosis type C: a retrospective follow-up study of 384 patients. *Gastroenterology*. 1997; 112: 463-472.
48. Sulkowski M, Gardiner D, Rodriguez-Torres M, Reddy R, Hassanein T, Jacobson I, et al. Daclatasvir plus Sofosbuvir for Previously Treated or Untreated Chronic HCV Infection. *The New England Journal of Medicine*. 2014; 370(3): 211-221.
49. UNITAID. Hepatitis C Medicines and Diagnostics in the Context of HIV/HCV Co-Infection: A Scoping Report. Geneva.; 2013.

Appendices

Table 1: Key Assumptions

a) Initial Fibrosis Distribution in Markov Model

Stage	Distribution	95 CI %	
F0	0.170	0.15 - 0.19	
F1	0.350	0.32 - 0.39	
F2	0.220	0.20 - 0.24	[41]
F3	0.140	0.13 - 0.15	
F4	0.120	0.11 - 0.13	
Decompensated Cirrhosis	0.010		Assumption
HCC	0.005		

b) Annualised Transition Probabilities

Transitions	Probabilities	95% CI	Source
Acute -> Spontaneous Recovery	0.250	0.150 - 0.500	[4]
Acute --> F0	0.750	0.500 - 0.850	
F0 --> F1	0.117	0.104 - 0.130	
F1 --> F2	0.085	0.075 - 0.096	[42]
F2 --> F3	0.120	0.109 - 0.133	
F3 --> F4	0.116	0.104 - 0.129	
F3 --> Decompensated	0.012	0.010 - 0.014	[43; 44]
F3 --> HCC	0.011	0.009 - 0.013	[43; 45]
F4 --> HCC	0.030	0.020 - 0.040	[43; 45]
F4 --> Decompensated	0.040	0.030 - 0.050	[43; 46; 44; 47]
Decompensated --> HCC	0.014	0.011 - 0.017	[43; 47]
Decompensated --> Liver Related Mortality	0.130	0.100 - 0.160	[43; 47]
HCC --> HCC Related Mortality	0.430	0.340 - 0.510	[43; 47]

c) Sustained Virological Response Rate SVR

	SVR (%)	Duration
Genotype 1	100	12 Weeks
Genotype 2	93	24 Weeks
Genotype 3	93	24 Weeks
Genotype 4	100	12 Weeks
Genotype 5	100	12 Weeks
Genotype 6	100	12 Weeks

Source: [48,49]

d) Other Assumptions

Scenarios	Treatment Groups	Subsidy Rates	Initial Diagnosis	Diagnosis/ Detection Factor	Absorption Capacity	Absorption Factor	Exogenous Rate of Price Reduction	Capacity to Pay (as % of Income)	Price Elasticity of Demand
Baseline	F3 + F4	0%	1% LIC, 3% LMIC, 5% UMIC	1.2	5%	1.2	3.8%	<= 40%	0.2, i.e. 10% decrease in price leads to a 2% increase in demand
Scenario 2	F0 to F4	0%							
Scenario 3	F3 + F4	25%							
		50%							
		75%							
Scenario 4	F3 + F4	80%		3		3			
Scenario 5	F0 to F4	80%		1.2		1.2			
Sensitivity Analysis	F0 to F4	0%							

i. The detection factor is the factor by which the number of people diagnosed increases over time.

ii. The absorption factor is the factor by which the number of infected individuals catered for by the health sector increases over time.

Table 2: Model Outcomes for Low-Income Countries

		Number Treated		HCV-Related Deaths		New HCV Infections	
		Total	Difference Compared with Baseline	Total	Percentage Difference Compared with Baseline	Total	Percentage Difference Compared with Baseline
Baseline	F3 + F4 OOPE	7 081	-	955 487	0,00%	2 777 177	0,00%
Scenario 2	F0 to F4 OOPE	7 081	-	955 487	0,00%	2 777 177	0,00%
Scenario 3	F3 + F4 OOPE reduced by 25% subsidy	37 686	30 604	954 639	-0,09%	2 776 334	-0,03%
	F3 + F4 OOPE reduced by 50% subsidy	91 708	84 627	951 343	-0,43%	2 773 260	-0,14%
	F3 + F4 OOPE reduced by 75% subsidy	139 975	132 893	943 990	-1,20%	2 767 643	-0,34%
	F3 + F4 OOPE reduced by 100% subsidy	145 357	138 276	942 413	-1,37%	2 766 847	-0,37%
Scenario 4	F3 + F4 OOPE reduced by 80% subsidy with improved diagnosis and strengthened health system	3 619 668	3 612 587	775 786	-18,81%	2 559 553	-7,84%
Scenario 5	F0 to F4 OOPE reduced by 80% subsidy with improved diagnosis and strengthened health system	9 497 902	9 490 820	773 084	-19,09%	2 236 468	-19,47%

i. Differences are calculated as a subtraction of the baseline result from the scenario results (Scenario Result – Baseline Result).

ii. The percentage differences are calculated as a ratio between this difference and the baseline result ((Scenario Result – Baseline Result)/Baseline Result).

iii. A negative (percentage) difference indicates better outcomes in the scenario compared with the baseline.

iv. Calculations made over a 10-year period.

Table 3: Model Outcomes for Lower-Middle-Income Countries

		Number Treated		HCV-Related Deaths		New HCV Infections	
		Total	Difference Compared with Baseline	Total	Percentage Difference Compared with Baseline	Total	Percentage Difference Compared with Baseline
Baseline	F3 + F4 OOPE	787 535	-	2 672 514	0,00%	7 832 116	0,00%
Scenario 2	F0 to F4 OOPE	826 872	39 337	2 672 464	0,00%	7 831 083	-0,01%
Scenario 3	F3 + F4 OOPE reduced by 25% subsidy	929 743	142 209	2 658 480	-0,53%	7 819 898	-0,16%
	F3 + F4 OOPE reduced by 50% subsidy	1 120 194	332 659	2 627 802	-1,67%	7 798 079	-0,43%
	F3 + F4 OOPE reduced by 75% subsidy	1 154 281	366 746	2 616 535	-2,09%	7 792 132	-0,51%
	F3 + F4 OOPE reduced by 100% subsidy	1 154 281	366 746	2 616 261	-2,10%	7 792 160	-0,51%
Scenario 4	F3 + F4 OOPE reduced by 80% subsidy with improved diagnosis and strengthened health system	13 103 802	12 316 267	1 604 713	-39,95%	6 651 065	-15,08%
Scenario 5	F0 to F4 OOPE reduced by 80% subsidy with improved diagnosis and strengthened health system	31 423 231	30 635 696	1 601 333	-40,08%	5 176 569	-33,91%

i. Differences are calculated as a subtraction of the baseline result from the scenario results (*Scenario Result – Baseline Result*).

ii. The percentage differences are calculated as a ratio between this difference and the baseline result ($(\text{Scenario Result} - \text{Baseline Result}) / \text{Baseline Result}$).

iii. A negative (percentage) difference indicates better outcomes in the scenario compared with the baseline.

iv. Calculations made over a 10-year period.

Table 4: Model Outcomes for Upper-Middle-Income Countries

		Number Treated		HCV-Related Deaths		New HCV Infections	
		Total	Difference Compared with Baseline	Total	Percentage Difference Compared with Baseline	Total	Percentage Difference Compared with Baseline
Baseline	F3 + F4 OOPE	1 377 901	-	1 652 121	0,00%	5 038 466	0,00%
Scenario 2	F0 to F4 OOPE	1 377 901	-	1 652 121	0,00%	5 038 466	0,00%
Scenario 3	F3 + F4 OOPE reduced by 25% subsidy	1 377 901	-	1 652 115	0,00%	5 038 467	0,00%
	F3 + F4 OOPE reduced by 50% subsidy	1 377 901	-	1 652 115	0,00%	5 038 467	0,00%
	F3 + F4 OOPE reduced by 75% subsidy	1 377 901	-	1 652 115	0,00%	5 038 467	0,00%
Scenario 4	F3 + F4 OOPE reduced by 100% subsidy	1 377 901	-	1 652 115	0,00%	5 038 467	0,00%
	F3 + F4 OOPE reduced by 80% subsidy with improved diagnosis and strengthened health system	8 999 414	7 621 514	885 819	-46,38%	4 176 820	-17,10%
Scenario 5	F0 to F4 OOPE reduced by 80% subsidy with improved diagnosis and strengthened health system	20 630 038	19 252 138	885 569	-46,40%	3 068 177	-39,10%

- i. Differences are calculated as a subtraction of the baseline result from the scenario results (Scenario Result – Baseline Result).
- ii. The percentage differences are calculated as a ratio between this difference and the baseline result ((Scenario Result – Baseline Result)/Baseline Result).
- iii. A negative (percentage) difference indicates better outcomes in the scenario compared with the baseline.
- iv. Calculations made over a 10-year period.

Table 5: Results from Monte-Carlo Simulations

	Mean	Std. Dev.	Min	Max
Low-Income Countries				
Number Treated	11 881 756	1 178 740	7 930 590	15 883 385
HCV-Related Death	956 937	116 708	580 847	1 518 637
New HCV Infections	2 820 206	259 111	1 988 242	3 708 681
Lower-Middle-Income Countries				
Number Treated	32 221 747	3 716 982	21 406 995	43 558 825
HCV-Related Death	1 663 036	224 659	997 583	2 577 542
New HCV Infections	5 386 147	627 012	3 707 795	7 668 104
Upper-Middle-Income Countries				
Number Treated	20 609 983	3 468 214	11 419 303	29 264 170
HCV-Related Death	915 902	164 414	537 534	1 542 838
New HCV Infections	3 113 891	565 713	1 933 251	5 236 299

- i. Results for Scenario 5 presented.*
- ii. 10 000 simulations were carried out in Excel 2010.*
- iii. Calculations made over a 10-year period.*

Figure 1: A Simplified Markov Model

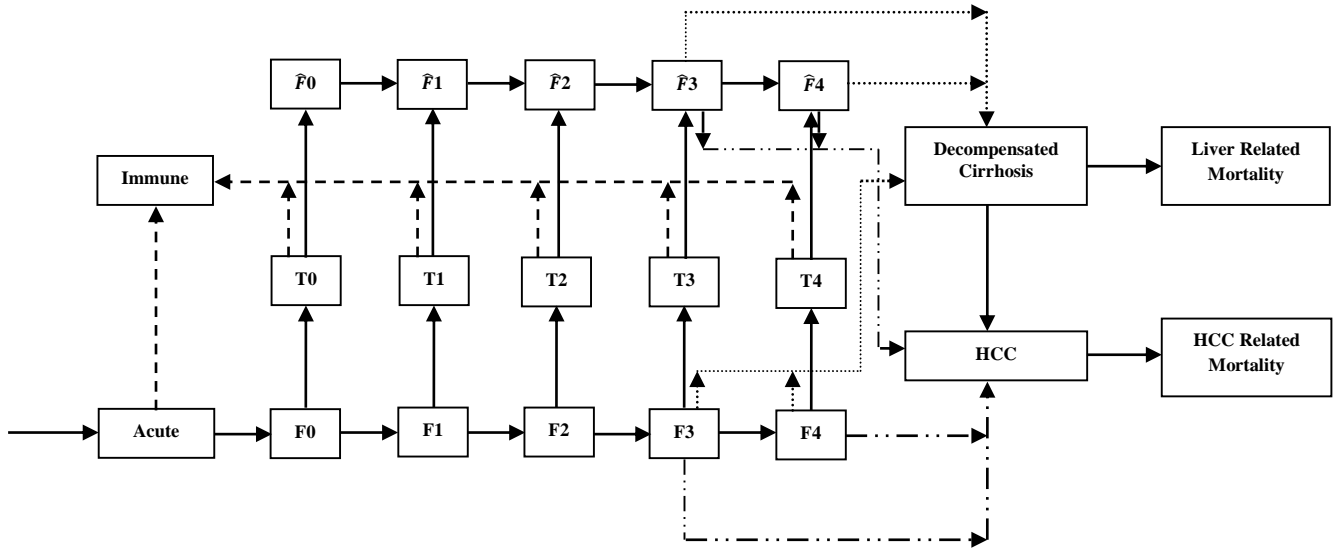
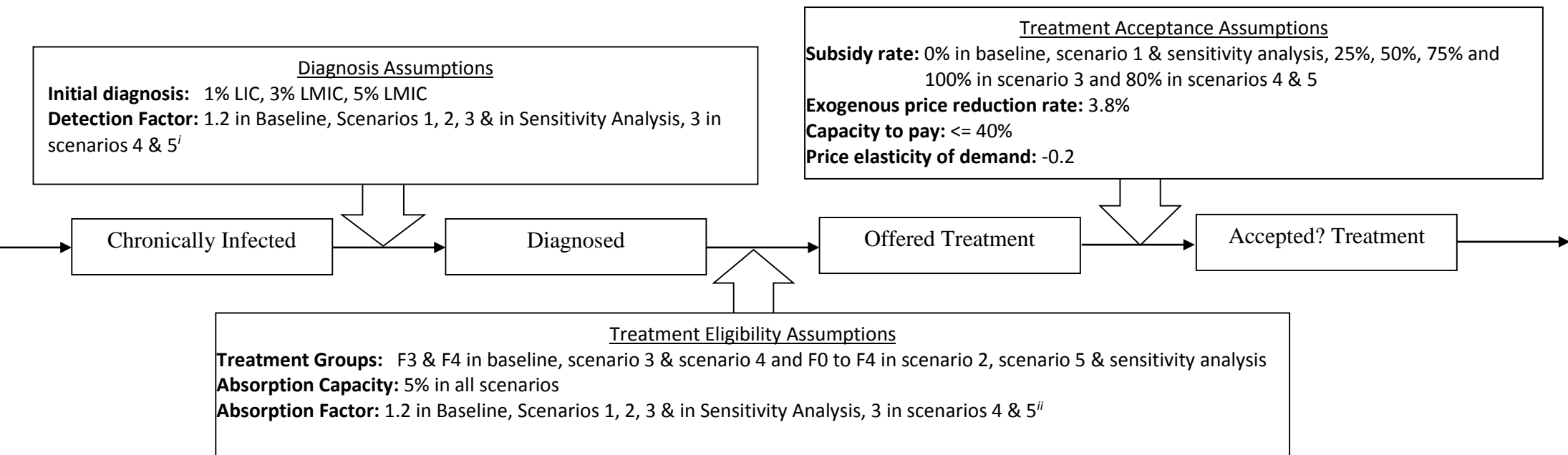
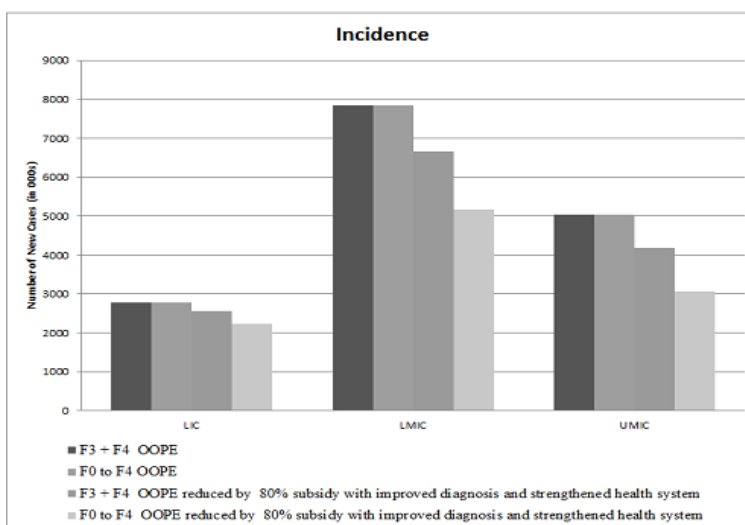
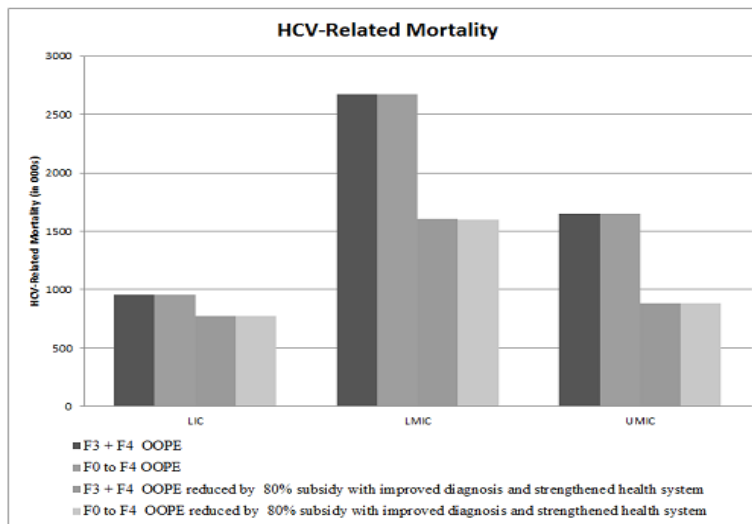
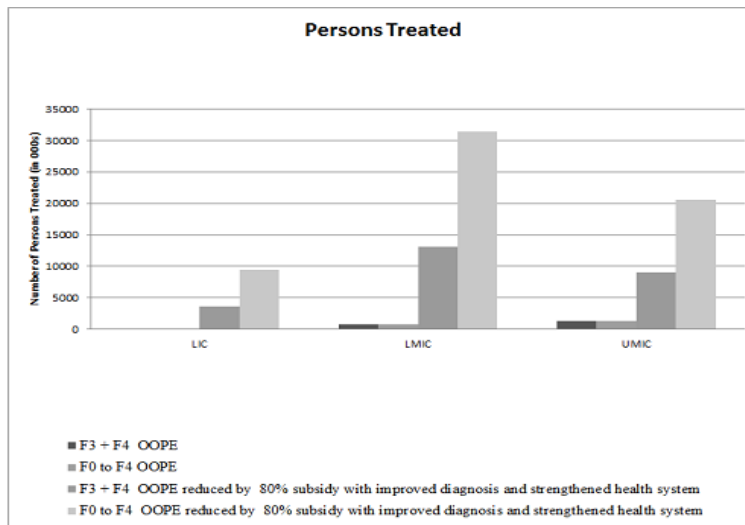

Figure 2: Assumptions Timeline



- i. The detection factor is the factor by which the number of people diagnosed increases over time.
- ii. The absorption factor is the factor by which the number of infected individuals catered for by the health sector increases over time.

Figure 3: Model Outcomes



- i. Results of subsidised model do not vary greatly from the baseline model and so are excluded.
- ii. Calculations made over a 10-year period.